

# alpha Rack&Pinion System

Operating Manual

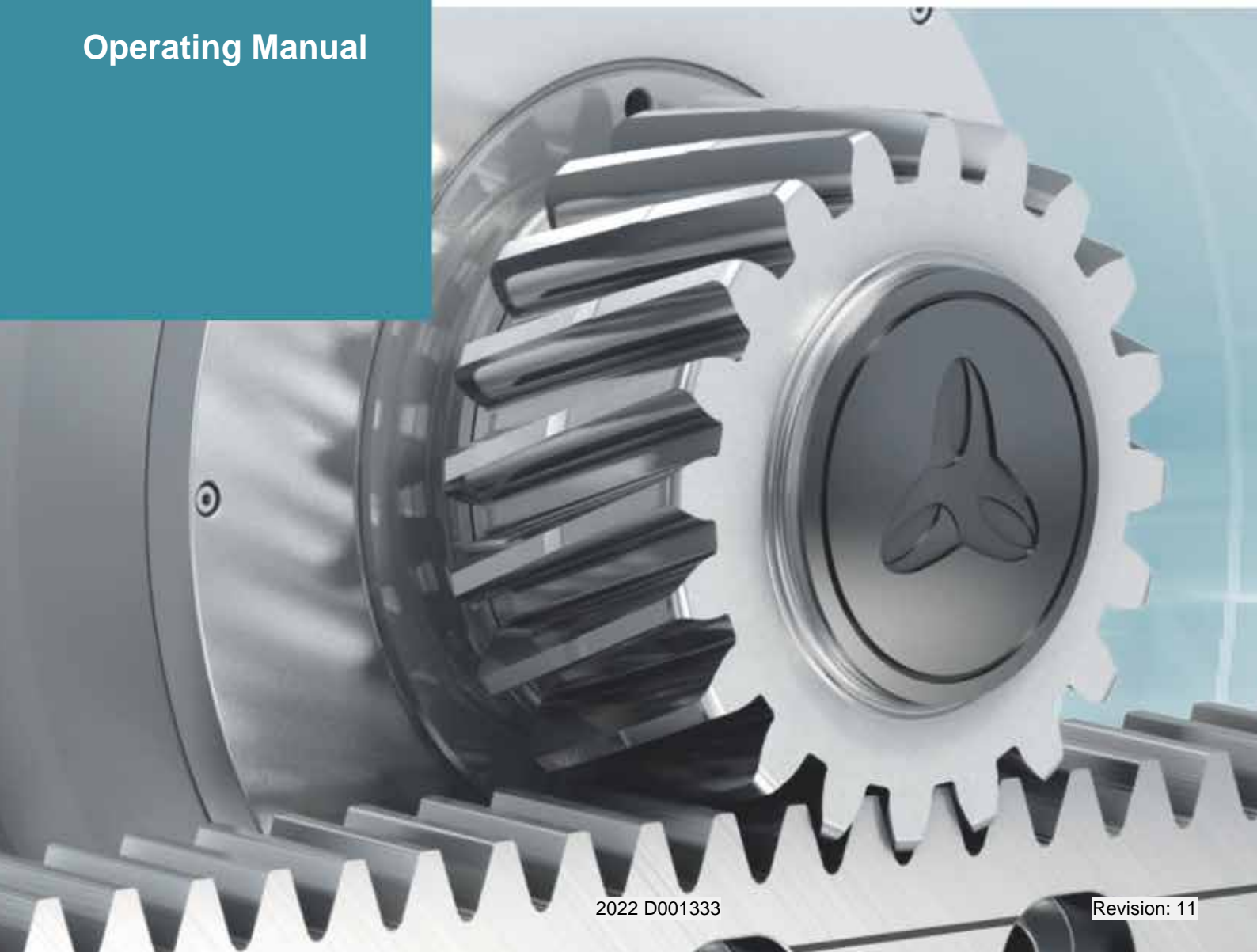

## Revision history

Revision	Date	Comment	Chapter
01	08/23/01	New version	All
02	10/18/05	Ordering code	4.5
03	11/10/06	Revision	All
04	12/14/06	Technical specifications	All
05	04/28/08	Chapter on lubricator added	11
06	04/22/09	Chapter on lubricator removed	11
07	12/16/10	Technical specifications	All
08	07/20/11	Revision	All
09	09/19/13	New safety instruction	3.3.1
10	10/21/16	Revision; new product line	All
11	02/28/17	Revision	5.4.3

## Service contact

In the event of technical questions, contact the following address:

**WITTENSTEIN alpha GmbH**  
 Customer Service department  
 Walter-Wittenstein-Straße 1  
 D-97999 Igersheim, Germany

Tel.: +49 7931 493-10900

Fax: +49 7931 493-10903

E-mail: [service-alpha@wittenstein.de](mailto:service-alpha@wittenstein.de)

## Copyright

© WITTENSTEIN alpha GmbH 2017

This documentation is copyright protected.

**WITTENSTEIN alpha GmbH** reserves all rights to photo-mechanical reproduction, copying, and the distribution by special processes (such as computers, file media, data networks), in whole or in part.

Subject to technical and content changes without notice.

## Contents

<b>1</b>	<b>About this manual</b>	<b>2</b>			
1.1	Signal words	2		5.8	Final inspection
1.2	Safety symbols	3		5.8.1	Contact pattern inspection
1.3	Design of the safety instructions	3		5.8.2	Checking the running characteristics after assembly
1.4	Information symbols	3		5.9	Mounting the lubrication system
<b>2</b>	<b>Safety</b>	<b>4</b>		5.9.1	Mounting the lubricating pinion on the lubricating axis
2.1	EC directives	4		5.9.2	Mounting the lubrication system
2.1.1	EC machinery directive	4		<b>6</b>	<b>Startup and operation</b>
2.1.2	RoHS	4		6.1	Safety instructions and operating conditions
2.2	Dangers	4		<b>7</b>	<b>Maintenance and disposal</b>
2.3	Personnel	4		7.1	Shutdown, preparation
2.4	Intended use	4		7.2	Maintenance schedule
2.5	Reasonably foreseeable misuse	4		7.3	Maintenance work
2.6	Guarantee and liability	5		7.3.1	Visual inspection
2.7	General safety instructions	5		7.3.2	Checking the lubrication system
<b>3</b>	<b>Description of the drive system</b>	<b>6</b>		7.4	Replacing the rack
3.1	Ordering code / label	7		7.4.1	Disassembling the rack
3.2	Performance data	7		7.4.2	Assembling the rack
3.3	Weight	7		7.4.3	Pinning the mounted and aligned rack
3.4	Noise emission	7		7.5	Startup after maintenance work
<b>4</b>	<b>Transport and storage</b>	<b>8</b>		7.6	Disassembly
4.1	Scope of delivery	8		7.6.1	Preparation
4.2	Packaging	8		7.6.2	Disassembling the rack
4.3	Transport	8		7.7	Lubricants
4.4	Storage	8		7.8	Disposal
<b>5</b>	<b>Assembly</b>	<b>9</b>		<b>8</b>	<b>Malfunctions</b>
5.1	Requirements in respect of installation location and mounting base	9		<b>9</b>	<b>Appendix</b>
5.2	Required tools and assembly material	10		9.1	Weight
5.3	Preparing for assembly	11		9.2	Cylinder head screws and cylindrical pins
5.3.1	After the cleaning	12		9.3	Requirements in respect of the assembly surfaces
5.4	Rack assembly	12		9.4	Permitted height tolerances at the rack transition
5.4.1	Assembling the first rack	13		9.5	Permissible deviations within an axis
5.4.2	Assembling subsequent racks	14		9.6	Assembly accessories
5.4.3	Checking the transition between the racks	15		9.7	Tightening torques for common thread sizes in general mechanical engineering
5.4.4	Assembling additional racks	15			
5.5	Checking the parallelism of all racks	16			
5.6	Pinning the racks	16			
5.7	Mounting the gearhead	17			
5.7.1	Inserting the gearhead at the highest point	18			

# 1 About this manual

This manual contains necessary information to safely use the rack&pinion system, hereinafter referred to as drive system.

If this manual is supplied with an amendment (e.g. for special applications), then the information in the amendment is valid. Contradictory specifications in this manual thereby become void.

The user should contact **WITTENSTEIN alpha GmbH** with any questions about special applications. The operator must ensure that this operating manual is read through by all persons assigned to install, operate or maintain the drive system and that they fully comprehend its content.

Store this manual within reach of the drive system. Inform colleagues who work in the area around the machine about the **safety instructions** so that no one is hurt.

The original manual was created in German; all other language versions are translations of these instructions.

## 1.1 Signal words

The following signal words are used to indicate possible hazards, prohibitions, and important information:

	<b>⚠ DANGER</b>
	<b>This signal word indicates an imminent danger that will cause serious injuries or even death.</b>

	<b>⚠ WARNING</b>
	<b>This signal word indicates a potential hazard that could cause serious injuries and even death.</b>

	<b>⚠ CAUTION</b>
	<b>This signal word indicates a potential hazard that could cause minor or serious injuries.</b>

	<b>NOTICE</b>
	<b>This signal word indicates a potential hazard that could lead to property damage.</b>

	<b>A note without a signal word indicates application hints or especially important information for handling the drive system.</b>
--	--

**1.2 Safety symbols**

The following safety symbols are used to indicate possible hazards, prohibitions, and important information:



General danger



Danger of being pulled in



Substances that represent a fire risk



Suspended loads



Environmental protection



Information

**1.3 Design of the safety instructions**

The safety instructions in this manual are designed according to the following pattern:

	<p><b>⚠ CAUTION</b></p>
	<p><b>Explanatory text describes the consequences of not complying with the instructions.</b></p> <ul style="list-style-type: none"> <li>Instructional text describes directly what to do.</li> </ul>

**1.4 Information symbols**

The following information symbols are used:

- Indicates an action to be performed
- Ü Indicates the results of an action
- i Provides additional information on handling

## 2 Safety

This operating manual, especially the safety instructions, and the rules and regulations valid for the operating site, must be observed by all persons working with the drive system.

In addition to the safety instructions in this manual, also observe any legal and otherwise applicable environmental and accident prevention rules and regulations (e.g. personal safety equipment).

### 2.1 EC directives

#### 2.1.1 EC machinery directive

The drive system is considered a "machine component" and is therefore not subject to the EC Machinery Directive 2006/42/EC.

Operation is prohibited within the scope of the EC directive until it has been determined that the machine in which this product is installed corresponds to the regulations within this directive.

#### 2.1.2 RoHS

The homogeneous materials used in the drive system do not exceed the limits for hazardous materials as per Directive 2011/65/EU Annex II.

- Lead (0.1%)
- Mercury (0.1%)
- Cadmium (0.01%)
- Hexavalent chromium (0.1%)
- Polybrominated biphenyls (PBB) (0.1%)
- Polybrominated diphenyl ether (PBDE) (0.1%)

Installation of the drive system therefore has no effect on the restriction of using certain hazardous materials in electrical and electronic equipment as required in the directive.

## 2.2 Dangers

The drive system has been designed and constructed according to current technological standards and accepted safety regulations.

To avoid danger to the operator or damage to the machine, the drive system may only be used as intended (see Chapter 2.4 "Intended use") and in a technically flawless and safe state.

Read the general safety instructions before beginning work (see Chapter 2.7 "General safety instructions").

## 2.3 Personnel

Only persons may carry out work on the drive system if they have read and understood this operating manual.

## 2.4 Intended use

The drive system is used to convert rotational motion to linear motion (e.g. for feed drives) or vice versa and is intended to be installed in a machine. It is suitable for industrial applications.

The drive system may not be operated in potentially explosive atmospheres. In food processing, the drive system may be used only next to or under the foodstuff area.

## 2.5 Reasonably foreseeable misuse





All other applications other than the intended use specified above, are deemed to be improper use and are not permitted.





## 2.6 Guarantee and liability

Any of the following will render void the guarantee and liability claims for personal injury or material damage

- Ignoring the information on transport and storage
- Improper use (misuse)
- Improper or neglected maintenance and repair
- Improper assembly/disassembly or improper operation (e.g. test run without secure attachment)
- Operation of the drive system when safety devices and equipment are defective
- Operation of the drive system without lubricant
- Operation of a heavily soiled drive system
- Changes or modifications executed without written approval of **WITTENSTEIN alpha GmbH**

## 2.7 General safety instructions

	<p style="text-align: center;"><b>⚠ WARNING</b></p> <p><b>Improperly executed work can lead to injury and damage.</b></p> <ul style="list-style-type: none"> <li>• Ensure that the drive system is only installed, maintained, and dismantled by trained technicians.</li> </ul>
	<p style="text-align: center;"><b>⚠ WARNING</b></p> <p><b>Objects projected by moving components can cause serious injuries.</b></p> <ul style="list-style-type: none"> <li>• Remove objects and tools from the drive system before putting it into operation.</li> </ul>
	<p style="text-align: center;"><b>⚠ WARNING</b></p> <p><b>Moving components on the drive system may pull in body parts, resulting in serious injuries or death.</b></p> <ul style="list-style-type: none"> <li>• Keep a sufficient distance to moving machine components when the drive system is running.</li> <li>• Secure the machine against restarting and unintentional movements during assembly and maintenance work.</li> </ul>
	<p style="text-align: center;"><b>⚠ WARNING</b></p> <p><b>A damaged drive system can cause accidents and injury.</b></p> <ul style="list-style-type: none"> <li>• Never use a drive system that has been overloaded due to misuse or a machine crash (see Chapter 2.5 "Reasonably foreseeable misuse").</li> <li>• Replace affected drive systems, even if no external damage is visible.</li> </ul>

	<p style="text-align: center;"><b>NOTICE</b></p> <p><b>Loose or overloaded bolted connections may cause damage to the drive system.</b></p> <ul style="list-style-type: none"> <li>Always use a calibrated torque wrench to tighten and check all bolted connections for which a tightening torque has been specified.</li> </ul>
	<p style="text-align: center;"><b>⚠ WARNING</b></p> <p><b>Lubricants are flammable.</b></p> <ul style="list-style-type: none"> <li>Do not spray with water to extinguish.</li> <li>Suitable extinguishing agents are powder, foam, water mist, and carbon dioxide.</li> <li>Observe the safety instructions of the lubricant manufacturer (see Chapter 7.3.2 "Checking the lubrication system").</li> </ul>
	<p style="text-align: center;"><b>⚠ CAUTION</b></p> <p><b>Solvents and lubricants can cause skin irritations.</b></p> <ul style="list-style-type: none"> <li>Avoid direct skin contact.</li> </ul>
	<p><b>Solvents and lubricants can pollute soil and water.</b></p> <ul style="list-style-type: none"> <li>Use and dispose of cleaning solvents and lubricants properly.</li> </ul>

### **3 Description of the drive system**

The drive system consists of:

- racks,
- the corresponding gearhead with a pinion at the output
- and a lubrication system.

The drive systems are available in different versions. Refer to our catalog or our website for the corresponding installation dimensions: [www.wittenstein-alpha.de](http://www.wittenstein-alpha.de).

For the assembly described in this operating manual, additional parts/tools are required which are available as separate accessories (see Chapter 9.6 "Assembly accessories").



### 3.1 Ordering code / label

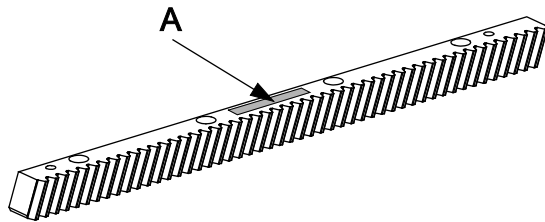

Fig. 3.1

The ordering code (A) for the racks is located on the racks (e. g.: ZST 200-XXX-1000-XXX-R11 or ZST 200-XXX-1000-R11).

- i Refer to our catalog or our website at [www.wittenstein-alpha.de](http://www.wittenstein-alpha.de) for further information.

The label for

- the gearhead is located on the gearhead housing.
  - the lubrication system is located on the lubricator.
- i Refer to our catalog, our website at [www.wittenstein-alpha.de](http://www.wittenstein-alpha.de) or the relevant manual for further information.

### 3.2 Performance data

For the maximum permitted speeds and forces, refer to

- our catalog,
- our website [www.wittenstein-alpha.de](http://www.wittenstein-alpha.de)
- the respective customer-specific performance data (2093–D...).

For additional information, contact **WITTENSTEIN alpha GmbH**. Always provide the ordering code / serial number.

	<p><b>Consult our Customer Service department if the drive system is older than one year. The user will then receive the valid performance data.</b></p>
--	--

### 3.3 Weight

The total weight of the drive system is the combination of the weight of the gearhead with the pinion and the corresponding racks.

- i For the weight of the individual racks, see Chapter 9.1 "Weight", Table 4.
- i For the weight of the gearhead and the lubricator (components of the lubrication system), refer to the relevant operating manual.

### 3.4 Noise emission

Depending on the gearhead type and product size, the continuous noise level generated by the drive system can be up to 72 dB(A).

- i For specifications on a particular product, the user should refer to our catalog, our website at [www.wittenstein-alpha.de](http://www.wittenstein-alpha.de) or contact our Customer Service department.
- Observe the total noise level of the machine.

## 4 Transport and storage

### 4.1 Scope of delivery

- Check the completeness of the delivery against the delivery note.
- i Immediately notify the carrier, the insurance company, or **WITTENSTEIN alpha GmbH** in writing of any missing parts or damage.

### 4.2 Packaging

Each rack is packaged in corrosion protected packaging.

The gearhead has a corrosion protection agent on the unpainted interfaces and on the mounted output pinion. It is packaged in foil inside cardboard boxes.

- Dispose of the packaging materials at the recycling sites intended for this purpose. Observe the applicable national regulations concerning disposal.

### 4.3 Transport

	<b>⚠ WARNING</b>
	<p><b>Suspended loads can fall and can cause serious injuries and even death.</b></p> <ul style="list-style-type: none"> <li>· Do not stand under suspended loads.</li> <li>· Secure the drive system before transport with suitable fasteners (e.g. belts).</li> </ul>

	<b>⚠ CAUTION</b>
	<p><b>There is a risk of injury or damage due to sharp edges on the rack.</b></p> <ul style="list-style-type: none"> <li>· Wear safety gloves and steel-capped boots.</li> </ul>

	<b>NOTICE</b>
	<p><b>Hard knocks, for instance because of falling or hard dropping, can damage the drive system.</b></p> <ul style="list-style-type: none"> <li>· Only use hoisting equipment and lifting accessories with sufficient capacity.</li> <li>· The maximum permissible lift capacity of a lifting device may not be exceeded.</li> <li>· Lower the drive system slowly.</li> </ul>

For specifications on the weight of the racks, see Chapter 9.1 "Weight", Table 4.

- i For the specifications on the weight of the gearhead and the lubricator, refer to the relevant manual.

### 4.4 Storage

Store the drive system in a horizontal position and dry surroundings at a temperature of 0 °C to +40 °C in the original packaging. Store the drive system for a maximum of 2 years.

For storage logistics, we recommend the "first in - first out" method.

## 5 Assembly

- Read the general safety instructions before beginning work (see Chapter 2.7 "General safety instructions").
- Observe the instructions in the relevant manual for the gearhead and lubrication system.

### 5.1 Requirements in respect of installation location and mounting base

Requirements in respect of installation location:

- The racks must be installed in a clean and dry environment. Dust and liquids of any kind impair its function.
  - The precision of installation and geometric tolerancing of the assembly surfaces on the mounting base depends on the application in question. For applications with high requirements regarding positioning accuracy and smooth running, the aim should be to achieve low deviations. For applications with low requirements, greater deviations may be allowed.
- i For assembly surface requirements, see Chapter 9.3 Requirements in respect of the assembly surfaces.

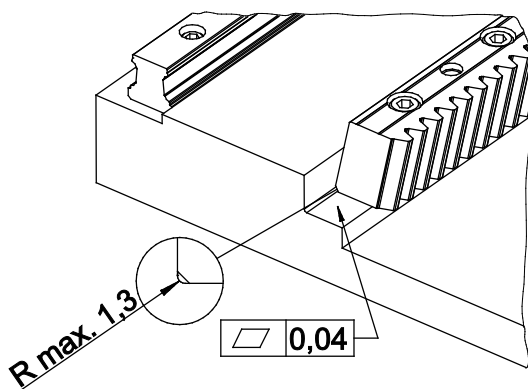

Fig. 5.1

Requirements in respect of mounting base:

- The rack is designed with a chamfer at the transition point between the screw-on and rear surface. This allows the mounting base to be designed without recesses. The mounting base on the machine must be designed in such a way that the milling edge does not collide with the rack chamfer (see Fig. 5.1).
  - The mounting base should be designed in such a way that facilitates the clamping of the assembly of the rack. This is achieved when the height of the stop surface is more than 50 % of the rack height and when a suitable counterface is available for clamping using a clamping device.
  - The required screw-in depths of the threaded holes for the fastening screws depend on the material of the mounting base.
- i Our Customer Service department is available to answer any questions regarding calculation of the screw-in depth.

**5.2 Required tools and assembly material**

Below is an overview of the tools / materials required for assembly.

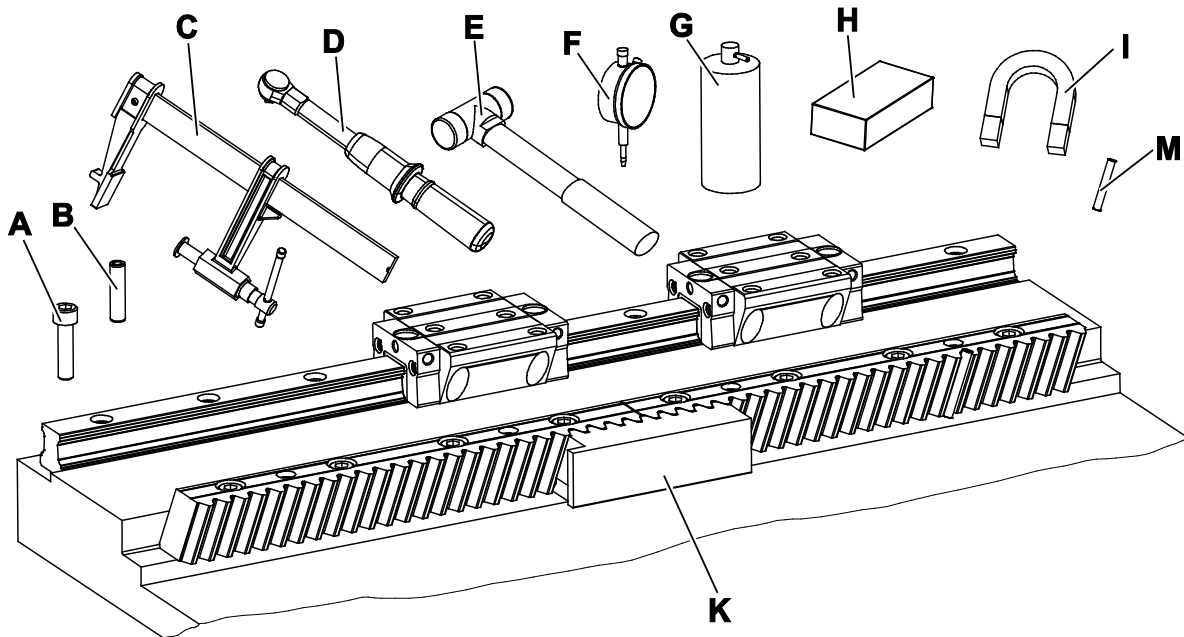



Fig. 5.2

Pos.	Tool / material	Task / purpose	Additional information
A	Fastening screws	To fix the racks to the screw-on surface	Required size: see Chapter 9.2 Cylinder head screws and cylindrical pins. The length of the fastening screws depends on the material of the mounting base on the machine. The number of fastening screws required depends on the bores provided in the rack.
B	Cylindrical pins	To pin the racks to the screw-on surface	Required size: see Chapter 9.2 Cylinder head screws and cylindrical pins. The length of the cylindrical pins depends on the material of the mounting base on the machine. The number of cylindrical pins required depends on the bores provided in the rack.
C	Clamping devices (e.g. screw clamps with protective caps)	To clamp the racks to the machine bed	-
D	Torque wrench with hex key insert	To tighten the fastening screws	Tightening torque: see Chapter 9.2 Cylinder head screws and cylindrical pins
E	Soft-faced hammer	To adjust the transition point between two racks	-
F	Dial gauge holder with dial gauge	To check the assembly surfaces and the assembled racks	Resolution: min. 0.01 mm

Pos.	Tool / material	Task / purpose	Additional information
G	Cleaning agent	To clean the assembly surfaces	-
H	Grinding stone		
I	Magnet	To magnetize the needle rollers	-
K	Assembly jig	To align the transition point between two racks	Size: see Chapter 9.6 Assembly accessories
M	Needle roller	To check the height deviation between racks using a dial gauge	Size: see Chapter 9.6 Assembly accessories

Table 1: List of necessary tools / materials

### 5.3 Preparing for assembly

	<h2>⚠ CAUTION</h2>
	<p><b>There is a risk of injury or damage due to falling racks and sharp edges on the rack.</b></p> <ul style="list-style-type: none"> <li>• Suitable lifting equipment should be used when transporting heavy racks.</li> <li>• When using lifting equipment, do not stand below the suspended load.</li> <li>• Wear protective gloves and safety shoes.</li> </ul>
	<ul style="list-style-type: none"> <li>• Observe the safety and processing instructions of the cleaning agents to be used.</li> </ul>

- Unpack the racks to be assembled and remove the VCI paper or protective foil in which the racks are wrapped.
- Check the ordering codes (see Chapter 3.1 "Ordering code / label") of all racks. Use only racks with the same ordering code for the same application.
- i Always enter the ordering code when ordering spare parts in order to receive racks and pinions which perfectly mate with each other.
- Remove all traces of the corrosion protection agent before mounting the racks. Use a clean, lint-free cloth and a grease-dissolving, non-aggressive cleaning agent.

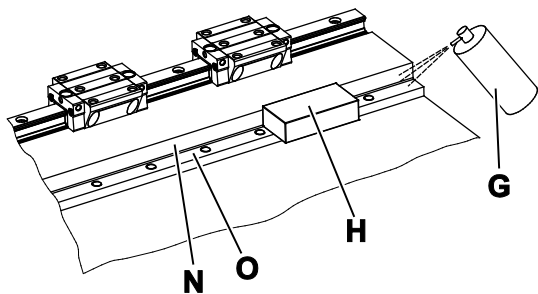

Fig. 5.3

- Clean the stop surface (N) and the screw-on surface (O) with a grinding stone (H), a suitable cleaning agent (G) and a lint-free cloth.

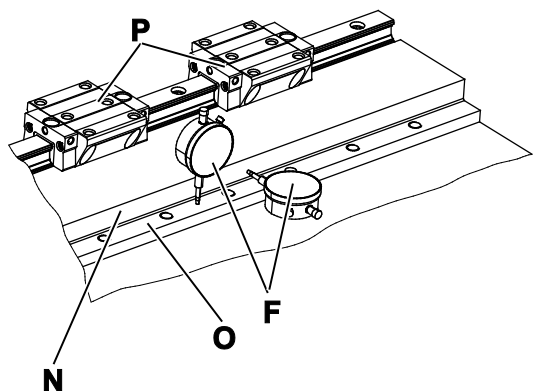

Fig. 5.4

- Check the parallelism between the stop surface (N) / screw-on surface (O) and the linear guide (P) with a dial gauge (F).
- i Observe the permissible tolerances in Chapter 5.1 Requirements in respect of installation location and mounting base.

### 5.3.1 After the cleaning

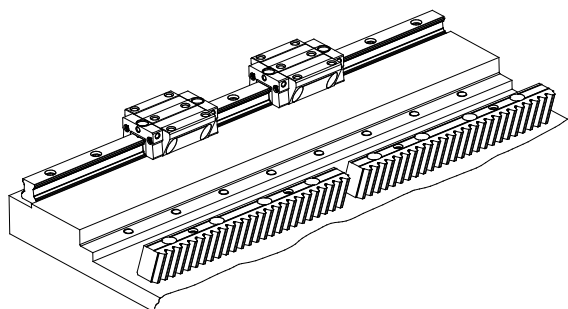

Fig. 5.5

Uneven temperatures between the racks and the mounting base can have a considerable impact on smooth running and positioning accuracy of the drive system.

- Place the unpacked racks on the mounting base an adequate time before assembly in order to allow the temperatures to equalize.

## 5.4 Rack assembly

	<b>NOTICE</b>
	<p><b>The improper use of clamping devices (e.g. such as screw clamps) can damage the toothing of the racks.</b></p> <ul style="list-style-type: none"> <li>· Only use clamping devices with protective caps or use intermediate layers of plastic or brass.</li> </ul>

- i Optimum precision of installation will be achieved through prior alignment of the linear guide or guide rails with the racks' assembly surfaces.

5.4.1 **Assembling the first rack**

	<ul style="list-style-type: none"> <li>• Only cylinder head screws in property class 12.9. are approved for fastening the racks.</li> <li>i For screw sizes and prescribed tightening torques, see Chapter 9.2 "Cylinder head screws and cylindrical pins", Table 5.</li> </ul>
--	---

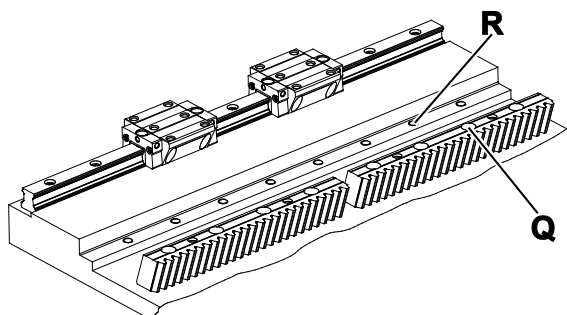

- Position the first rack in the middle of the machine bed.
- i The through bore holes (Q) of the rack must be centered above the corresponding threaded holes (R) of the screw-on surface.

Fig. 5.6

- i It is recommended that the user starts installation in the center of the axis, particularly in the case of a long axis. If installation starts at the end of the axis, pitch deviation of the racks and position deviations of the bores can accumulate to such an extent that the through bore holes in the racks and the threaded holes in the mounting base no longer are aligned.

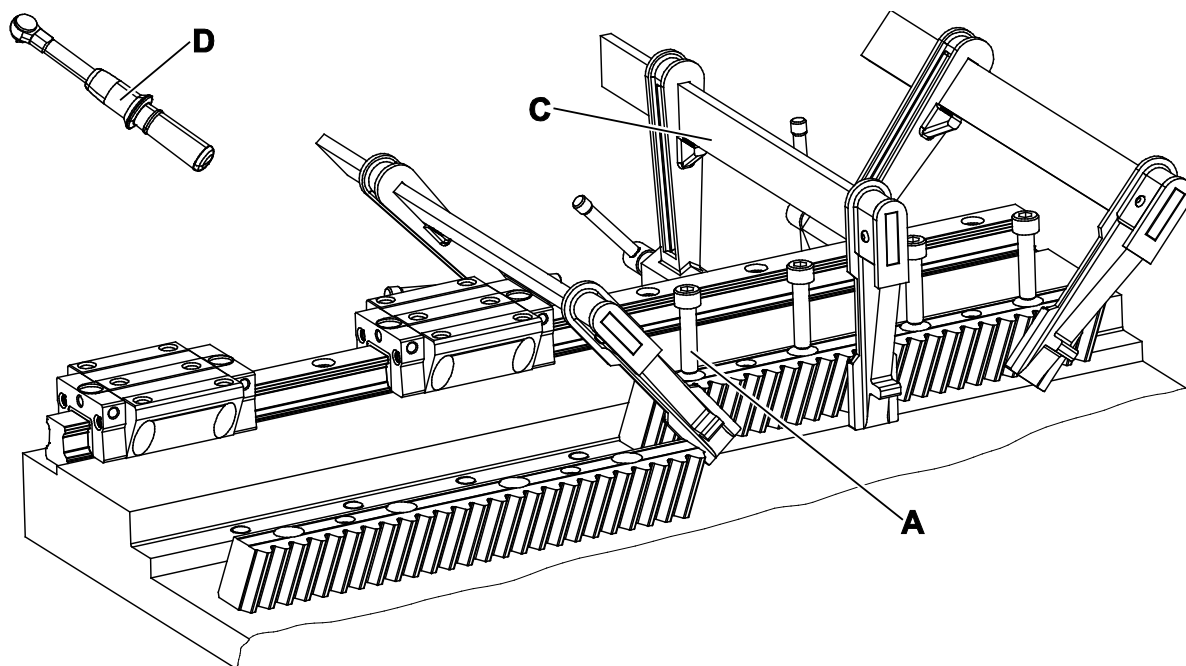

Fig. 5.7

- Clamp the rack to the machine bed in the area of the fastening bores using clamping devices (C).
- Insert the first cylinder head screw (A).
- i To secure the cylinder head screws, we recommend using a thread locking glue (e.g. Loctite® 243).
- Tighten the cylinder head screws with the required tightening torque, while the clamping device (in the following simply called screw clamp) holds the position.
- i For screw sizes and prescribed tightening torques, see Chapter 9.2 "Cylinder head screws and cylindrical pins", Table 5.
- Repeat the previous steps for the remaining cylinder head screws.
- i For screw sizes and prescribed tightening torques, see Chapter 9.2 "Cylinder head screws and cylindrical pins", Table 5.
- Remove the screw clamps.

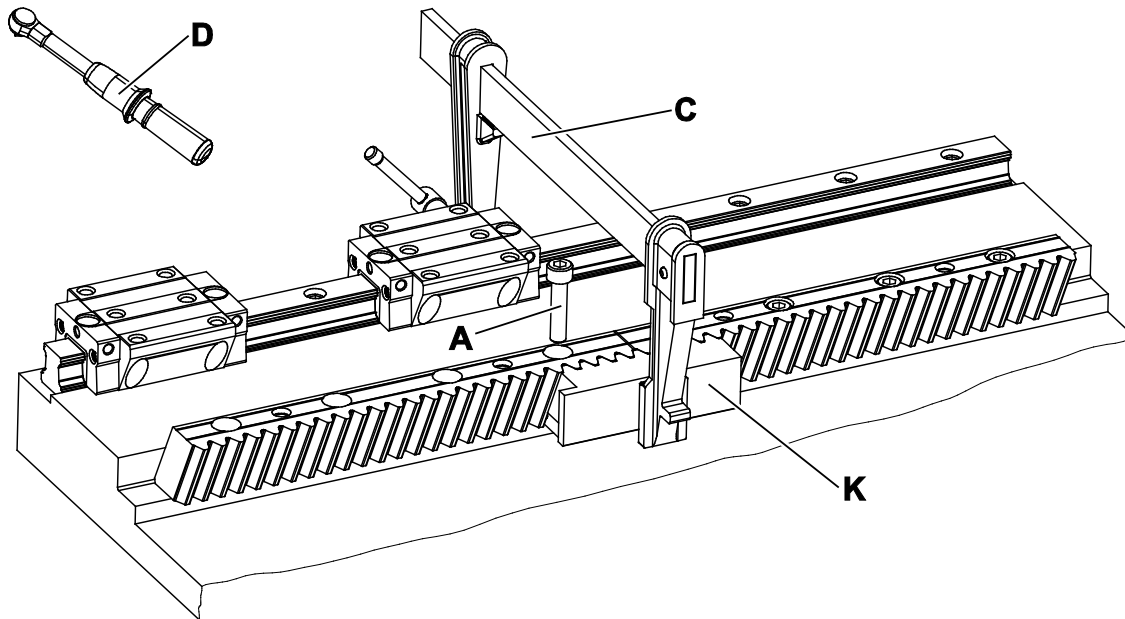



Fig. 5.8

- Ü If the pressing force on the assembly jig is too high at the transition between two racks, the rack gap can widen. The assembly jig should serve only as an insert between two racks.
  - Position the rack to be assembled beside the previously assembled rack.
  - Insert the assembly jig (K) into both racks at the transition point, in order to adjust the transition between the two racks.
  - Clamp the rack to the machine bed in the area of the through bore holes.
  - Insert the first cylinder head screw (A) in assembly direction.
- i To secure the cylinder head screws, we recommend using a thread locking glue (e.g. Loctite® 243).
  - Tighten the cylinder head screw in assembly direction with half of the predetermined tightening torque.
- i For screw sizes and prescribed tightening torques, see Chapter 9.2 "Cylinder head screws and cylindrical pins", Table 5.
  - Repeat the previous steps for the remaining cylinder head screws.
  - Loosen all screw clamps (C) and the assembly jig.
- Ü Check the flatness of the joint as described in Chapter 5.4.3 "Checking the transition between the racks" before mounting the next rack.



### 5.4.3 Checking the transition between the racks

	NOTICE
<p><b>A rack can be permanently magnetized by placing the dial gauge holder on it.</b></p> <ul style="list-style-type: none"> <li>· Fasten the dial gauge holder on the guiding carriage or the machine slide only.</li> </ul>	

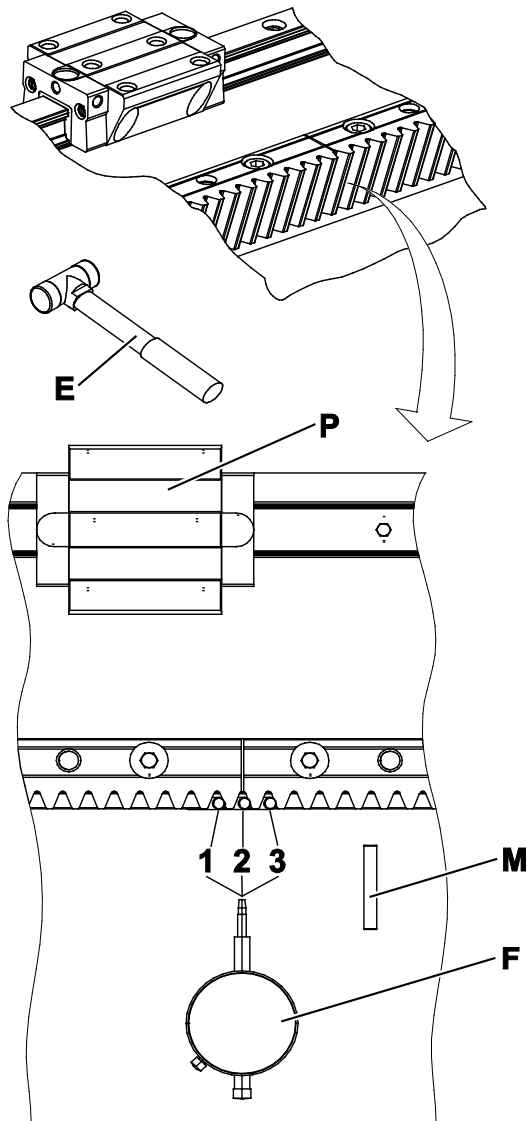

Fig. 5.9

- Magnetize the needle rollers (M) with a suitable magnet.
- Insert the magnetized needle rollers into positions 1, 2 and 3, as shown in the figure.
- i Due to the magnetization, the needle rollers remain attached to the positions.
- Attach the dial gauge holder to the guiding carriage (P) and insert the dial gauge.
- Measure the highest point at each of the needle rollers at position 1 and position 3 using the dial gauge (F), and calculate the average value of the two points.
- i The average value is the target value for the highest point of the needle roller at position 2.
- i For the maximum permissible height deviation from position 1 to position 3, see Chapter 9.4 "Permitted height tolerances at the rack transition".
- Measure the highest point of the needle roller at position 2 with the dial gauge.
  - If the value is **outside** of the tolerance range, correct the transition between the two racks by hitting them in the corresponding direction with a copper punch and/or a soft-headed hammer (E). To do this, place the copper punch on one of the rack's fastening bores.
- After successful checking of the butt joint, clamp only the vises tight again and tighten the cylinder head screws with the full tightening torque (see Chapter 9.2 "Cylinder head screws and cylindrical pins", Table 5).

### 5.4.4 Assembling additional racks

- Assemble all additional racks in the same manner as described in the chapters above.

### 5.5 Checking the parallelism of all racks

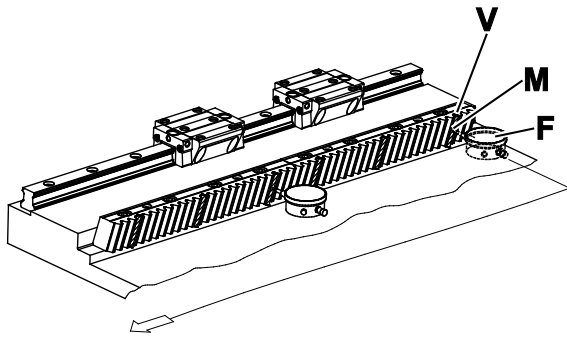

- Attach the dial gauge holder to the guiding carriage and move this to the end of the axis.
- Place a magnetized needle roller (M) into a tooth gap at the outer end of the axis.
- Position the dial gauge (F) on the peak of the needle roller and set the dial gauge to zero.
- Mark the measurement value at the point of measurement (V) (reference point) with a pen on the rack.

Fig. 5.10

- Insert needle rollers into tooth gaps at regular intervals (at least 5 needle rollers per 1000 mm of axis length).
- Check the deviation from the reference point with the dial gauge.
- Label the deviation from the reference point at each point of measurement.
- i For permissible deviations within an axis, see Chapter 9.5 Permissible deviations within an axis.
- i Identify the highest point of measurement of the entire axis and mark this.
- i The "highest point" is required for correct adjustment of the gearing backlash between the pinion and the rack.

### 5.6 Pinning the racks

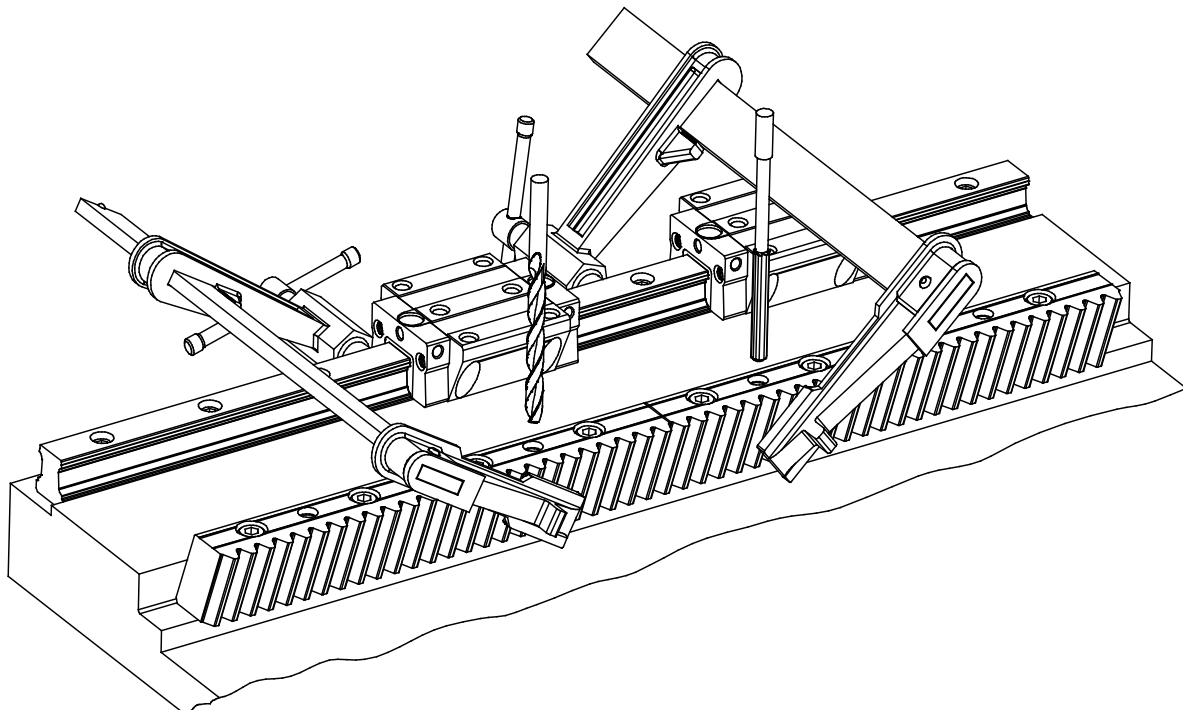
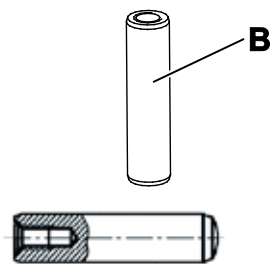

Fig. 5.11

- Pre drill the pin holes in the mounting base on the machine at the locations provided.
- i The pin holes are pre-drilled in the racks by the manufacturer. The diameter of the pin holes in condition of delivery is lower than the final dimension to be achieved.
- Clamp the rack tightly at all pin holes using clamps.

- Ream the bores in the rack and the machine bed together to the required fit size for the cylindrical pins (see Chapter 9.2 "Cylinder head screws and cylindrical pins").
- i The tolerance range for the bores is H7. For specifications on the diameters of cylindrical pins, see Chapter 9.2 Cylinder head screws and cylindrical pins.
- i Remove the accumulating chips with a vacuum cleaner.



- i To enable easier disassembly of the rack, cylindrical pins (B) with internal threads are recommended.
- Fasten the racks with cylindrical pins.
- i If it is not possible to pin the racks, contact our Customer Service department.



Fig. 5.12

• If the machine is not to be put into operation immediately, conserve the racks using a suitable corrosion protection agent.

### 5.7 Mounting the gearhead

The gearhead is delivered with the mounted pinion. To ensure an easy assembly procedure, we recommend not mounting the motor until the rack&pinion system has been adjusted and checked.

The machine's gearhead interface should be designed in such a way that assembly and aligning (e.g. with an adjusting tool) should be easy.

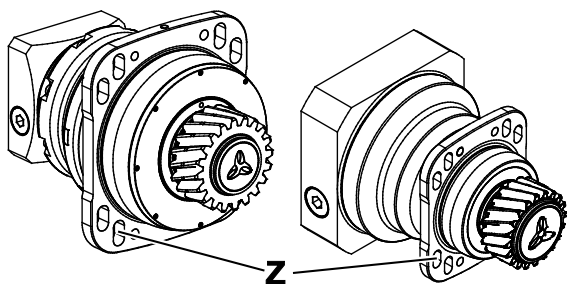

When employing a gearhead with integrated slotted holes (Z) in the gearhead flange no additional adjusting device is necessary.

- i More information about assembly and mounting interfaces of these interfaces can be found in the relevant operating manual..

Fig. 5.13

**5.7.1 Inserting the gearhead at the highest point**

The gearhead can be installed in any mounting position.

The highest point, i.e. the tooth with the greatest radial runout deviation, is marked on the output pinion by the manufacturer.

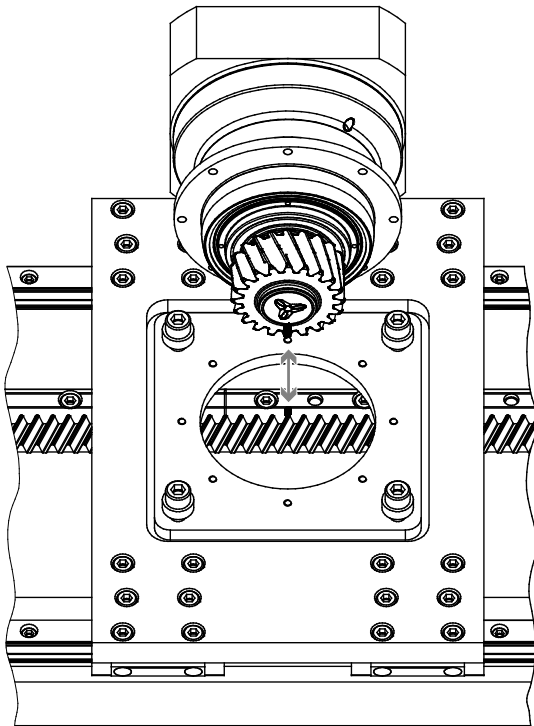

Fig. 5.14

- Align the "highest points" of the pinion and rack with one another using the machine's adjusting device.
- Slide the gearhead pinion unit into the rack by hand. The tooth flanks of the pinion and rack should be free of backlash and without pretension at their "highest points".
- Apply thread locking glue to the screws and fix the gearhead.

**Adjusting the gearhead**

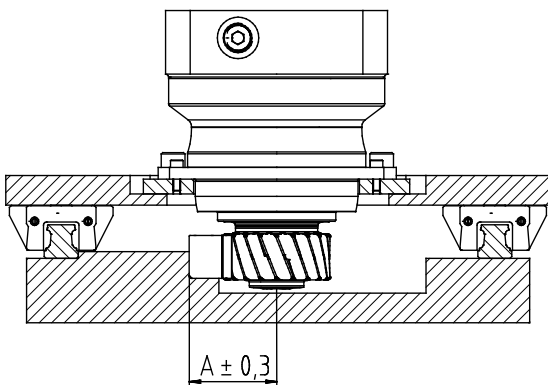

Fig. 5.15

- i Refer to our catalog or our website for distance dimension "A":  
[www.wittenstein-alpha.de](http://www.wittenstein-alpha.de).

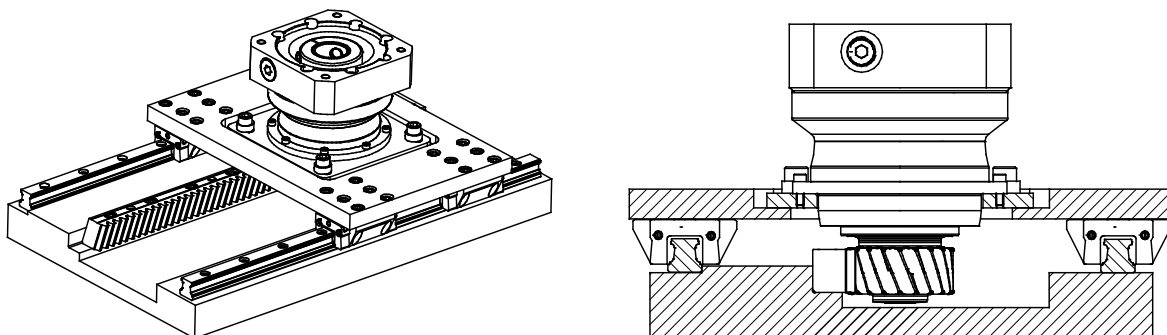

Fig. 5.16

Backlash is possible in some segments of the travel path. Distortion of toothed parts is **not** permitted.

## 5.8 Final inspection

### 5.8.1 Contact pattern inspection

	<ul style="list-style-type: none"> <li>Observe the safety and processing instructions of the cleaning agents to be used.</li> </ul>
--	---

- Degrease the tooth flanks of the rack (e.g. with acetone).
- Coat the tooth flanks with gear marking compound or with a water-proof pen.
- Shift or move the slide several times so that the pinion runs over the coated tooth flanks.
- Ü Check that the gearing runs smoothly.
- Ü Check in which range the color is removed from the tooth flanks.
- Ü Evaluate the alignment of the gearhead based on the following illustrations.
- If necessary, correct the alignment of the gearhead.
- i Oil or grease all blank parts with a cloth against corrosion.

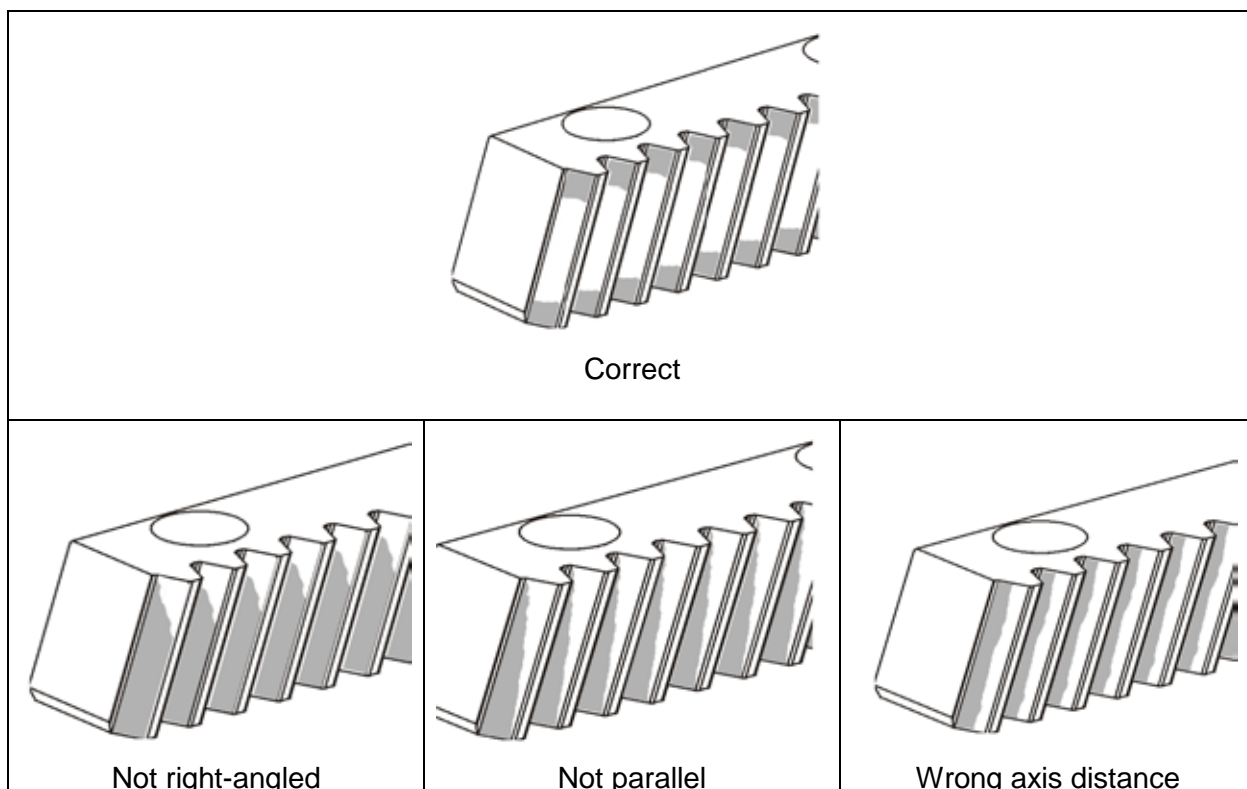

### 5.8.2 Checking the running characteristics after assembly

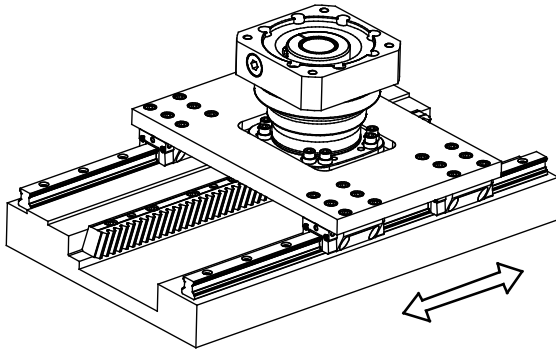

- Shift or move the slide several times across the entire movement range.
- i The force required for moving the machine slide and the running noise of the machine slide need to remain stable.
- i Use a hand wheel or crank connected to the clamping hub in the gearhead to move the slide. Consult our Customer Service department to receive further information.

Fig. 5.17

### 5.9 Mounting the lubrication system

- |  |   |
|--|---|
|  | <ul style="list-style-type: none"> <li>· Read the general safety instructions in the lubricator's manual and in Chapter 2.7 "General safety instructions" before beginning work.</li> </ul> |
|--|---|

The rack&pinion system is lubricated by a lubrication system, which dispenses lubricant onto the pinion and/or rack through a lubricator by means of a plastic hose line and a lubricating pinion.

- i The lubricator is filled with grease that is optimized for the application and approved by WITTENSTEIN.
- i The recommended, adjustable quantity of lubricant depends on the application. This can be found in the catalog, on our website [www.wittenstein-alpha.de](http://www.wittenstein-alpha.de) or can be requested from WITTENSTEIN alpha's Customer Service department.

#### 5.9.1 Mounting the lubricating pinion on the lubricating axis

The lubricating pinion is made of PU foam and is delivered dry.

- i We recommend that our standard lubricants WITTENSTEIN alpha G11, G12, and G13 are used for lubrication.
- Grease the lubricating pinion. To do so, place the lubricating pinion in the lubricant for an extended period.
- i This is necessary in order to avoid damage to the gearing and the slide bearing between the lubricating pinion and lubricating axis.

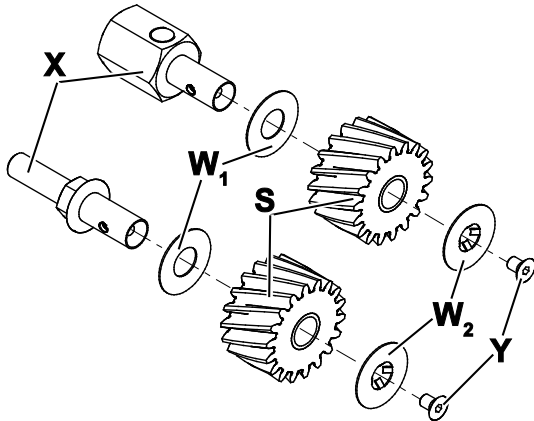

Fig. 5.18

- Slide the flat washer disk (W1) on to the shaft of the lubricating axis (X).
- Grease the lubricating axis slightly.
- Slide the pre-greased lubricating pinion (S) on the shaft of the lubricating axis.
- Ü Check that there is enough grease between the lubricating axis and the slide bearing on the lubricating pinion.
- Insert the flat head screw (Y) into the second washer disk (W2).
- Moisture the flat head screw with a thread locking glue (e.g. Loctite® 243).
- Screw the washer disk onto the lubricating axis using the flat head screw. Align the washer disk.
- i The permissible tightening torque is 6 Nm.

**5.9.2 Mounting the lubrication system**

<b>i</b>	<p>The maximum length of the plastic hose line for grease lubrication using the LUC+ 400 lubricator is 10 m.</p> <p>The minimum bending radius for plastic hose lines is 30 mm.</p> <p>The minimum bending radius for plastic hose lines laid in a cable chain is 40 mm.</p>
----------	--

- Calculate the axis distance between the pinion and lubricating pinion approximately using the following formula:

$\text{Axis distance} = \frac{d \text{ lubricating pinion} + d_A \text{ pinion}^a)}{2}$
---

or

$\text{Axis distance} = \frac{d \text{ lubricating pinion}}{2} + h \text{ rack}$
--

<sup>a)</sup>  $d_A \text{ pinion} = d \text{ pinion} + 2 * x * m$   
 $d \text{ pinion}$  = Reference diameter pinion [mm]  
 $x$  = Profile shift factor  
 $m$  = Normal module [mm]

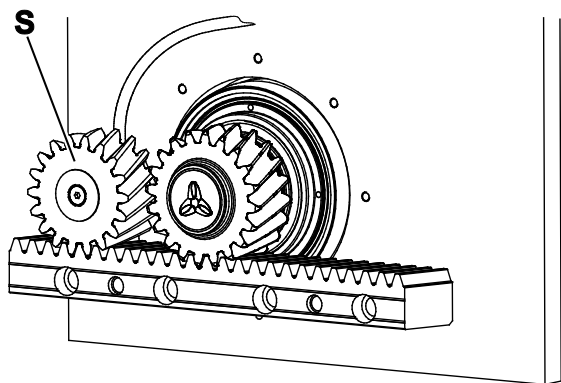

Fig. 5.19

- Mount the lubricating axis with the installed lubricating pinion (S), without pretensioning on pinion or rack, onto the mounting base.
- i To secure the screws, we recommend using a thread locking glue (e.g. Loctite® 243).

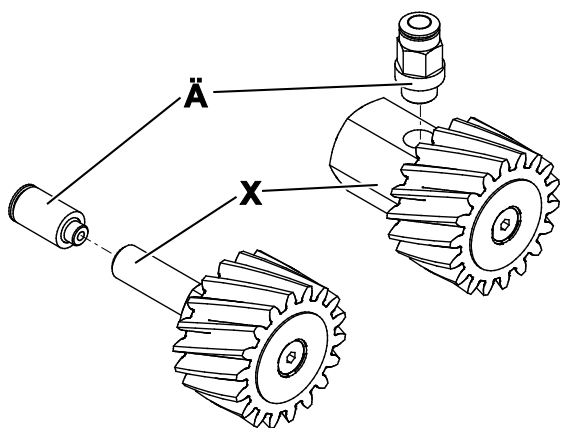

Fig. 5.20

- Ü Check that the O-ring is mounted correctly on the hose connector.
- Screw the hose connector (Ä) into the lubricating axis (X).

- Put the plastic hose up to the stop in the hose connector. The correct insertion depth is 18 mm.
- i Install the bubble-free filled plastic hose so that it cannot be kinked during operation.
- i Use a special hose cutter to cut the plastic hose. This ensures a straight cut and avoids damage to the hose.
- i Refer to our catalog or our website for specifications on the installation dimensions: [www.wittenstein-alpha.de](http://www.wittenstein-alpha.de)
- Close off plastic hoses that are not being used with the hose end caps provided.

<b>NOTICE</b>	
	<p><b>Too little or incorrect lubrication of the drive system damages the gearing.</b></p> <ul style="list-style-type: none"> <li>▪ Always ensure sufficient lubrication with a suitable lubricant.</li> <li>▪ Grease the racks and the pinion before startup.</li> <li>▪ Replace the lubricant cartridge in the lubricator in time.</li> </ul>

- i Further information on the lubricator can be found in the relevant operating manual.
- i Special operating conditions may make different lubricants and lubricant quantities necessary. In this case, consult our Customer Service department.



## 6 Startup and operation

### 6.1 Safety instructions and operating conditions

- Read the general safety instructions before beginning work (see Chapter 2.7 "General safety instructions").
- Observe the instructions in the relevant manual for the gearhead and lubrication system.

<b>NOTICE</b>	
	<p><b>Insufficient lubrication upon startup of the drive system damages the gearing.</b></p> <ul style="list-style-type: none"><li>• Always make sure that there is sufficient lubrication and exchange the lubricant cartridge in the lubricator in time.</li></ul>

	<p><b>Improper use can cause damage to the drive system.</b></p> <ul style="list-style-type: none"><li>• Ensure that<ul style="list-style-type: none"><li>- the <b>ambient temperature</b> does not drop below +10 °C or exceed +40 °C and</li><li>- the <b>operating temperature</b> does not exceed +90 °C.</li></ul></li><li>• For other conditions of use, consult our Customer Service department.</li><li>• Only use the drive system up to its maximum limit values, see Chapter 3.2 "Performance data".</li><li>• Use the drive system only in a clean, dust-free and dry environment.</li></ul>
--	--

## 7 Maintenance and disposal

- Read the general safety instructions before beginning work (see Chapter 2.7 "General safety instructions").
- Observe the instructions in the relevant manual for the gearhead and lubrication system.

### 7.1 Shutdown, preparation

- Shut down the machine that contains the drive system.
- Disconnect the machine from the power supply before starting maintenance work.

### 7.2 Maintenance schedule

Maintenance work	At startup	After 500 operating hours or 3 months	Every 3 months
Visual inspection and cleaning	X	X	X
Checking the lubrication system	X	X	X

Table 2: Maintenance schedule

### 7.3 Maintenance work

#### 7.3.1 Visual inspection

- Check the entire drive system by carrying out a thorough visual inspection for exterior damage and sufficient lubrication.
- Repair or replace defective parts immediately.
- i For special information on maintenance-related issues, contact our Customer Service department.

#### 7.3.2 Checking the lubrication system

	<b>NOTICE</b>
	<p><b>Too little lubrication damages the toothing.</b></p> <ul style="list-style-type: none"> <li>· Always make sure that there is sufficient lubrication and exchange the lubricant cartridge in time.</li> </ul>

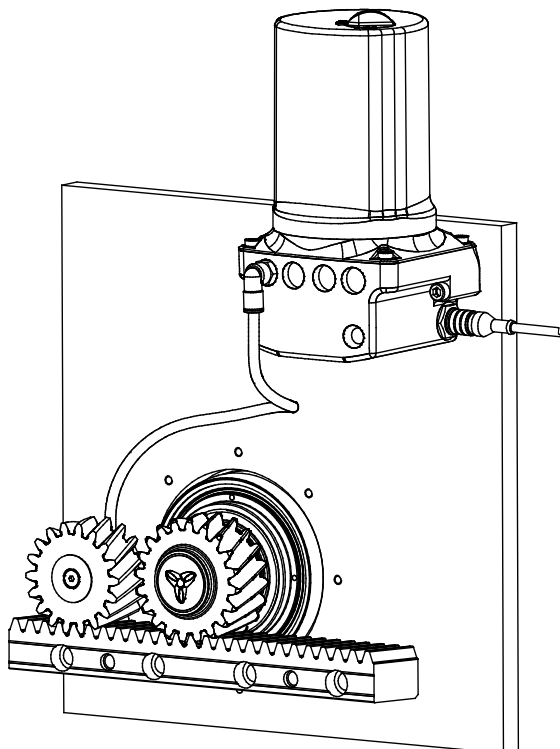



Fig. 7.1

- Check the entire lubrication system by carrying out a thorough visual inspection for exterior damage such as loosened or defective hoses and worn or soiled (clogged) lubricating pinions.
- Replace damaged parts immediately to ensure a continuous lubrication.
- The service life of the lubricating pinion depends on the ambient conditions.
- Check the fill level in the lubricator.

- i Further information on the lubricants in the gearhead and in the lubricator can be found in the relevant operating manual.

#### 7.4 Replacing the rack

	⚠ CAUTION
	<p><b>There is a risk of injury or damage due to falling racks and sharp edges on the rack.</b></p> <ul style="list-style-type: none"> <li>• Suitable lifting equipment should be used when transporting heavy racks.</li> <li>• When using lifting equipment, do not stand below the suspended load.</li> <li>• Wear protective gloves and safety shoes.</li> </ul>

NOTICE
<p><b>Avoid heat transfer to the racks during assembly.</b></p> <ul style="list-style-type: none"> <li>• Wear protective gloves during assembly.</li> </ul>

<p><b>Improper replacement of a rack can cause damage to the drive system and the neighboring parts.</b></p> <ul style="list-style-type: none"> <li>• Make sure that the rack is replaced by trained technicians.</li> </ul>
--

### 7.4.1 Disassembling the rack

- Remove the pins of the racks with a suitable tool.
- Loosen all fastening screws and remove the rack.
- Remove the rack with care, so as to safeguard the drive system and adjacent parts against damage.

### 7.4.2 Assembling the rack

- Use only racks with the same ordering code for the same application.
- Carry out the assembly of the new rack as described in Chapter 5.4.2 Assembling subsequent racks.
- Ü During the assembly of the rack, check the transitions to the adjacent racks.

### 7.4.3 Pinning the mounted and aligned rack

- Clamp the rack tightly at all pin holes using screw clamps.
- Select the cylindrical pin one size larger than specified in Chapter 9.2 Cylinder head screws and cylindrical pins.
  - i Only the standard sizes are specified in Chapter 9.2 Cylinder head screws and cylindrical pins.
- Drill and grind the rack and machine bed to the required fit size.
  - i The tolerance range for the bores is H7.
  - i For an easier disassembly, we recommend the cylindrical pins with internal treads.
  - i Remove the accumulating chips with a vacuum cleaner.
- Fasten the racks with cylindrical pins.
- If a pinning of the racks is not possible, consult our Customer Service department.

## 7.5 Startup after maintenance work

- Clean and grease the racks and the pinion.
- Attach all safety devices.
- Do a test run before re-releasing the machine for operation.

## 7.6 Disassembly

	<p>▲ CAUTION</p>
<p><b>Improperly executed work can lead to injury and damage.</b></p> <ul style="list-style-type: none"> <li>• Ensure that the drive system is only installed, maintained, and dismantled by trained technicians.</li> </ul>	

- i The disassembly of the gearhead and lubricator is described in the relevant operating manuals.

### 7.6.1 Preparation

- Shut down the machine that contains the drive system.
- Ensure that it is possible to dismantle the drive system without constituting a damage hazard for the whole machine.
- Before starting work, disconnect the machine from the power supply.

### 7.6.2 Disassembling the rack

- Carry out the disassembly of the racks as described in Chapter 7.4.1 Disassembling the rack.

## 7.7 Lubricants



**Solvents and lubricants are hazardous substances that can contaminate soil and water.**

- Use and dispose of cleaning solvents and lubricants properly.
- Do not mix polyglycol with mineral oils that are intended for recycling.

- Remove all deposits of lubricant from the individual racks.
- Dispose of the lubricant deposits and the racks at the appropriate disposal sites.
- i Observe the applicable national regulations concerning disposal.

## 7.8 Disposal

Consult our Customer Service department for supplementary information on disposal of the drive system.

- Dispose of the drive system at the appropriate disposal sites.
- i Observe the applicable national regulations concerning disposal.

## 8 Malfunctions

	NOTICE
	<p><b>Changed operational behavior can be an indication of existing damage to the drive system or can cause damage to the drive system.</b></p> <ul style="list-style-type: none"> <li>• Take action immediately if lubricant loss, increased operating noise, increased operating temperatures, frictional corrosion on tooth flanks, broken teeth or position deviations become noticeable within the travel path.</li> <li>• Do not put the drive system back into operation until the cause of the malfunction has been rectified.</li> </ul>

	<p>Rectifying of malfunctions may only be done by specially trained technicians.</p>
---	--

Fault	Possible cause	Solution
<b>Increased operating temperature</b>	Drive system overloaded	Check the technical specifications
	Motor is heating the gearhead.	Check the controller's settings.
	Ambient temperature too high.	Ensure adequate cooling.
<b>Increased operating noises</b>	Distorted motor/gearhead unit	Consult our Customer Service department.
	Damaged bearings	
	Damaged gear teeth	
	Distorted rack&pinion unit	
	Imprecise rack assembly	
<b>Loss of lubricant</b>	Lubricant quantity too high	Change the settings on the lubricator and wipe away excess lubricant. Information for setting the automated lubrication amount/duration can be found in the manual for the lubricator.
	Leakage	Consult our Customer Service department.
<b>Bubbles in the lubricant feed line</b>	Lubricant quantity too low	Change the settings on the lubricator. Information for setting the automated lubrication amount/duration can be found in the instructions of the lubricator. As an alternative, the use of a check valve is possible. Contact our Customer Service department for this.

Fault	Possible cause	Solution
<p><b>Frictional corrosion on tooth flanks</b></p>	<p>Leak of lubrications</p>	<p>Install a lubricating pinion on the output pinion or rack. Make sure on short travel paths that the meshing points on the output pinion and racks are lubricated sufficiently. Information for setting the automated lubrication amount can be found in the manual for the lubricator.</p>
	<p>Ambient influences</p>	<p>The rack always has to be installed in a clean and dry environment and protect the rack against outer influences (e.g. chips, cleaning agents)</p>
	<p>Wrong lubricant</p>	<p>Use only lubricants that have been approved by us.</p>
<p><b>Broken teeth</b></p>	<p>Overload</p>	<p>Check the dimensioning for normal and emergency stop conditions.</p>
	<p>Machine collision</p>	
	<p>External medium</p>	<p>Check the output pinion / rack for possible external medium (e.g. chips, forgotten assembly tools)</p>
	<p>Insufficient lubrication</p>	<p>Always ensure sufficient lubrication. Information for setting the automated lubrication duration can be found in the manual for the lubricator.</p>
	<p>Position of the output pinion compared to the rack</p>	<p>Carry out a contact pattern inspection (see Chapter 5.8.1 Contact pattern inspection). Correct the alignment of the gearhead if necessary.</p>
<p><b>Position deviation or great flank backlash within the travel path</b></p>	<p>Wrong alignment between output pinion and rack</p>	<p>Correct the axis distance (highest point of the output pinion to highest point of the rack) and the alignment of the gearhead/rack.</p>

Table 3: Malfunctions

## 9 Appendix

### 9.1 Weight

Weight <b>helically toothed</b> racks [kg]							
Length [mm]	Module 1.5 mm	Module 2.0 mm	Module 3.0 mm	Module 4.0 mm	Module 5.0 mm	Module 6.0 mm	Module 8.0 mm
167	-	0.7	-	-	-	-	-
250	-	-	1.5	-	-	-	-
333	-	1.4	-	-	-	-	-
480	-	1.9	2.7	4.7	-	-	21.0
500	1.3	2.1	3.0	-	6.5	9.9	-
506	-	-	-	5.4	-	-	-
960	-	-	-	-	-	-	42.0
1000	2.5	4.1	5.9	10.7	13.1	19.9	-
1500	3.8	6.2	8.9	-	19.5	27.1	-
2000	5.0	8.2	11.0	21.4	26.0	36.2	-
Weight <b>straight toothed</b> racks [kg]							
Length [mm]	Module 1.5 mm	Module 2.0 mm	Module 3.0 mm	Module 4.0 mm	Module 5.0 mm	Module 6.0 mm	Module 8.0 mm
167 - 2000	on request						

Table 4: Weight

### 9.2 Cylinder head screws and cylindrical pins

Cylinder head screw EN ISO 4762, property class 12.9			Cylindrical pin with interior thread Shape A acc. to DIN 7979 or EN ISO 8735	
Bore [mm]	Thread	Tightening torque [Nm]	Bore [mm]	Diameter [mm]
Ø 7	M6	15.4	Ø 5.7	6 m6
Ø 10	M8	37.3	Ø 7.7	8 m6
Ø 12	M10	73.4	Ø 9.7	10 m6
Ø 14	M12	126	Ø 11.7	12 m6
Ø 18	M16	310	Ø 15.7	16 m6
Ø 22	M20	604	Ø 19.7	20 m6

Table 5: Cylinder head screws and cylindrical pins



### 9.3 Requirements in respect of the assembly surfaces

Rack module [mm]	Parallelism deviation [ $\mu\text{m}$ ]		
	Requirements in respect of positioning accuracy and smooth running		
	High	Normal	Low
1.5	10	15	30
2.0	10	15	30
3.0	10	15	30
4.0	10	15	30
5.0	10	15	30
6.0	10	15	30
8.0	10	15	30

Table 6: Parallelism deviation of the assembly surfaces

### 9.4 Permitted height tolerances at the rack transition

Rack module [mm]	Roll size deviation [ $\mu\text{m}$ ]		
	Requirements in respect of positioning accuracy and smooth running		
	High	Normal	Low
1.5	10	15	25
2.0	10	15	30
3.0	15	20	40
4.0	15	20	45
5.0	20	25	45
6.0	20	25	50
8.0	20	30	55

Table 7: Measurement over pins between two neighboring tooth gaps at the rack transition

### 9.5 Permissible deviations within an axis

Rack module [mm]	Roll size fluctuation [ $\mu\text{m}$ ]		
	Requirements in respect of positioning accuracy and smooth running		
	High	Normal	Low
1.5	30	45	80
2.0	30	45	85
3.0	35	50	100
4.0	40	55	110
5.0	40	60	120
6.0	40	60	120
8.0	50	70	130

Table 8: Recommended measurement over pins variations within an axis

### 9.6 Assembly accessories

Rack module [mm]	Assembly jig		Needle roller	
	Size	Order number	Diameter [mm]	Order number
1.5	ZMT 150	20064154	2.5 <sup>0</sup> / <sub>-0.002</sub>	20006839
2.0	ZMT 200	20020582	3.5 <sup>0</sup> / <sub>-0.002</sub>	20001001
3.0	ZMT 300	20021966	5.0 <sup>0</sup> / <sub>-0.002</sub>	20000049
4.0	ZMT 400	20037466	7.0 <sup>0</sup> / <sub>-0.002</sub>	20038001
5.0	ZMT 500	20037469	9.0 <sup>0</sup> / <sub>-0.002</sub>	20038002
6.0	ZMT 600	20037470	10.0 <sup>0</sup> / <sub>-0.002</sub>	20038003
8.0	ZMT 800	20052289	14.0 <sup>0</sup> / <sub>-0.002</sub>	20052298

Table 9: Assembly accessories

### 9.7 Tightening torques for common thread sizes in general mechanical engineering

The specified tightening torques for headless screws and nuts are calculated values and are based on the following conditions:

- Calculation in accordance with VDI 2230 (February 2003 version)
- Friction value for thread and contact surfaces  $\mu = 0.10$
- Exploitation of the yield stress 90%
- Torque tools type II classes A and D in accordance with ISO 6789

The settings are values rounded to usual commercial scale gradations or setting possibilities.

- Set these values precisely on the scale.

Property class screw / nut	Tightening torque [Nm] with thread												
	M3	M4	M5	M6	M8	M10	M12	M14	M16	M18	M20	M22	M24
8.8 / 8	1.15	2.64	5.2	9.0	21.5	42.5	73.5	118	180	258	362	495	625
10.9 / 10	1.68	3.88	7.6	13.2	32.0	62.5	108	173	264	368	520	700	890
12.9 / 12	1.97	4.55	9.0	15.4	37.5	73.5	126	202	310	430	605	820	1040

Table 10: Tightening torques



WITTENSTEIN alpha GmbH · Walter-Wittenstein-Straße 1 · 97999 Igersheim · Germany  
Tel. +49 7931 493-12900 · [info@wittenstein.de](mailto:info@wittenstein.de)

**WITTENSTEIN - one with the future**

**[www.wittenstein-alpha.de](http://www.wittenstein-alpha.de)**